

POWER OF 1 SERVICE**

A. O. Smith is committed to respond to the customer's problem within 1 hour of the call being registered on the toll free number. The problem experienced by the customer is to be rectified within one working day. And the solution will be provided the first time itself.



Toll Free No.: **1800-103-2468** or
SMS us: **+91 99410 32468** or
Email us: **aosmithcs@aosmithindia.com**
Monday to Friday: 9 am to 8 pm.
Saturday & Sunday: 9 am to 6 pm.

A. O. SMITH: THE COMPANY

A. O. Smith has been setting new standards for India's water heater industry.

A. O. Smith India Water Products Private Limited was established in 2006. Since then, the A. O. Smith team has conducted numerous focus group studies and spent endless research hours determining what India wanted in a water heater. Backed by 75 years of proven technological advances, A. O. Smith India has created a stylish design with features demanded by the Indian consumer.

The A. O. Smith plant with manufacturing facilities started with 76,000 sq. ft. is located on 20 acres, just outside Bengaluru, in the KIADB Industrial Area, Harohalli. The India operations is the 16th A. O. Smith manufacturing facility worldwide. In 2013 additional 150,000 sq.ft. has been added in Bengaluru factory. A. O. Smith's India plant has extensive engineering and technical resources and has the latest technologies incorporated. A. O. Smith is the first manufacturer to invest in and produce glass-lined water heaters in India.

Today, A. O. Smith Corporation is one of the largest water heater manufacturers in the world and is a global leader in innovative technology and energy efficient solutions.



***Extended Warranty**

Registration of Extended Warranty (1 year or 2 years) is valid if customer registers the product within 60 days of purchase. Please call our toll free no. 1800-103-2468 or fill up the details in our website link (<http://www.aosmithindia.com/warranty-form.aspx>) to register.

****Power of 1 Service**

Calls requested with A. O. Smith Customer Care Centre on working days before 4 pm | Within city municipal limits only | Restricted to service requests only | Available only in following cities: Ahmedabad, Bangalore, Chandigarh, Chennai, Cochin, Delhi, Faridabad, Ghaziabad, Goa, Gurgaon, Hyderabad, Kolkata, Noida, Pune | Service may impact due to: natural calamities, public holidays and under unavoidable conditions due to political and regional regulations.

Contact your friendly A. O. Smith dealer today:



REGISTERED OFFICE:

Manufactured by **A. O. Smith India Water Products Private Limited**

(formerly known as A. O. Smith India Water Heating Private Limited)

Plot No. 300, Phase - II, KIADB Industrial Area, Harohalli, Kanakapura Taluk, Ramanagara District, Karnataka – 562 112, India.

CIN: U31909KA2006PTC040282

www.aosmithindia.com



Fit it & Forget it

Higher energy rating.
Longer warranties.

WHY PEOPLE PREFER AN A. O. SMITH WATER HEATER...



ADVANCED TECHNOLOGY

Blue Diamond® glass lined tank. Maximum protection against hard water and corrosion.



SUPERIOR QUALITY

Get the best quality that ensures, you have a water heater that works in Indian water conditions.



LONGER WARRANTIES

7 years warranty on inner tank, 4 years extended warranty* on glass coated heating element & 2 years comprehensive.



ENERGY SAVING

BEE 5 star rating*. One of the most energy efficient water heaters you can buy.



MADE BETTER

Made in India's most modern and advanced water heater factory.

* Conditions apply, refer to last page



Featured model HSE-SDS is available in 6, 15 & 25 litre capacities.

KEY FEATURES



- 1 GLASS COATED HEATING ELEMENT**

Scale and sediment build-up on the surface of the element can lead to premature failure. A. O. Smith Glass Coating helps to prevent scale formation and extends the life of the heating element.
- 2 BLUE DIAMOND® GLASS LINING**

Blue Diamond® technology increases the life of the inner tank. The lining is stronger and more corrosion resistant than any other in the industry.
- 3 ANODE ROD**

The tank has an anode rod which has stainless steel core that is designed to protect the tank from corrosive elements. The anode rod uses a special cathodic action to fight these elements and thus prolong the life of the water heater.
- 4 TEMPERATURE CONTROL KNOB**

The temperature control knob allows you to set the temperature anywhere between 25°C to 75°C.
- 5 THERMAL CUTOUT**

If the water temperature exceeds the highest preset level, the thermal cutout cuts off the power supply to assure safety.
- 6 SAFETY VALVE**

The safety valve [not seen in picture] is designed to automatically relieve and discharge water, in case the pressure overshoots the preset limits.
- 7 FOUR YEARS EXTENDED WARRANTY**

The tank carries a 7 years warranty. The heating element has a 2 years warranty that can be extended to 4 years if registered within the first 60 days of purchase. All other parts carry a 2 years warranty. (Warranty applies only if the water heater is purchased from our authorised dealer)

A. O. SMITH COLOURMATCH SYSTEM®



Colours shown are only indicative and may vary from actual colours available.

The product of your choice comes with either white or ivory body colours, along with the same coloured front panels.

The A. O. Smith ColourMatch System® allows your water heater to match the colours of your bathroom. Call the A. O. Smith Customer Care Centre [1800-103-2468] to register your product within 60 days of purchase and ask for one of the Decorative Front Panel colour options which will be delivered to you at no cost. This option is available only once, on a purchase.

HSE-SDS 6, 15 & 25 Litres



SPECIFICATIONS

MODEL	HSE-SDS-006	HSE-SDS-015	HSE-SDS-025
Volume [L]	6	15	25
Power [kW]	2	2	2
Voltage/Frequency [V/Hz]	230~/50	230~/50	230~/50
Temperature range [°C]	25-75	25-75	25-75
Rated water pressure [Bar]	8	8	8
Reheating time for 35°C rise [in min.]	6	18	29
Actual stdg. loss [kWh/24h/45°C diff.]	0.341	0.451	0.550
Net Weight [kg]	6.3	9.81	12.99

DIMENSIONS

MODEL	HSE-SDS-006	HSE-SDS-015	HSE-SDS-025
A [mm]	317	373	444
B1 [mm]	317	373	444
B2 [mm]	348	405	483
C [mm]	258	348	383

PART DESCRIPTORS

1 Outlet	8 Anode
2 Inlet	9 Heating Element
3 Safety Valve	10 Tank
4 Temperature Controller Knob	11 Installation Bracket
5 Decorative Front Panel	12 PU Insulation
6 Front Jacket	13 Thermal Cutout
7 Back Jacket	

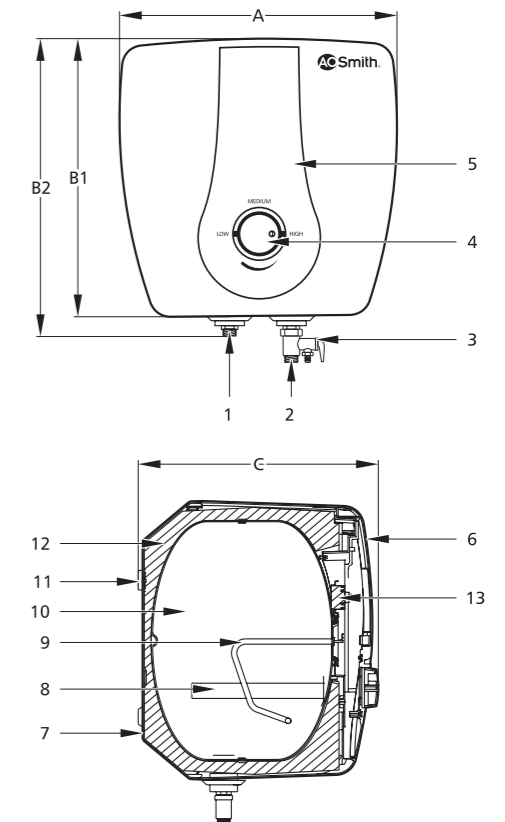

Note: A. O. Smith reserves the right to amend or modify the specifications and features at any time, as and when required without any prior notification.