

Presenting

# X5<sup>+</sup>NEO

Untouched. Unseen.  
Unbelievable benefits.

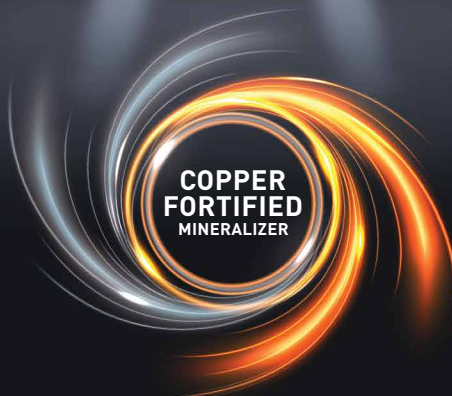



Fits seamlessly with your modern modular kitchen decor.



Healthy drinking water with RO+CFM Technology & 6 stages of purification.



Peace of mind with 1 year comprehensive warranty.



## Get Health the Copper way with 6 Stage Purification

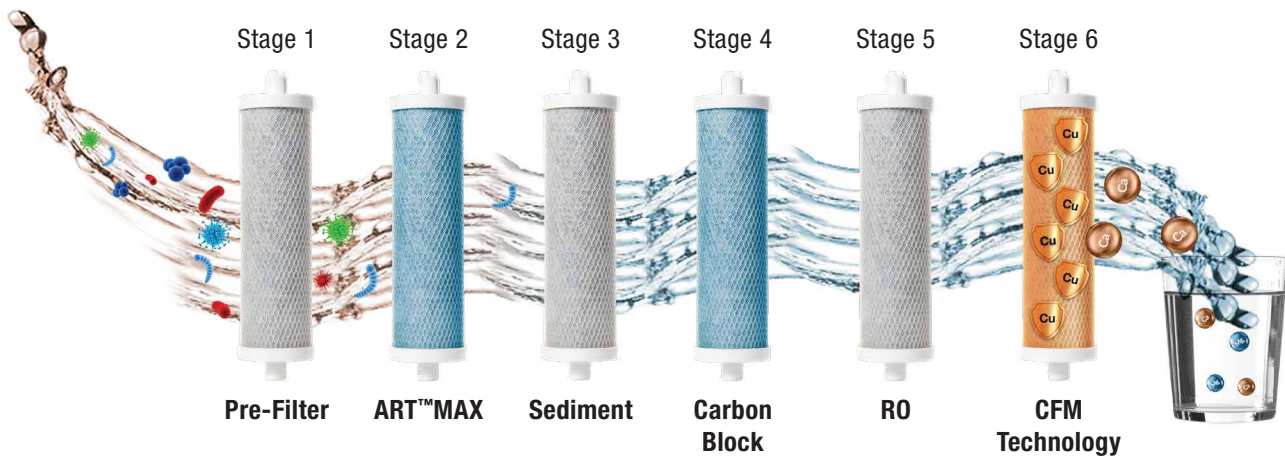

X5+Neo is designed to fit in seamlessly with your modern modular kitchen decor. X5+Neo keeps your kitchen clutter-free, maximizes cabinet space while ensuring you get 100% RO purified water with all essential minerals & benefits of copper in it.

### Specifications

Dimension (H x D x W) in mm	455 x 200 x 310
Storage Capacity	6 Litres
Pressure rating in psi <sup>#</sup>	7 ~ 30
Input Voltage in watt	150 ~ 300V AC / 50 Hz
Power rating watt (Max)	48
% Recovery <sup>#</sup>	Min. 40%
TDS reduction <sup>#</sup>	≥95% (approx.)
Water flow rate	Upto 15 Litres/hour
Suitable for TDS level	Upto 2000 ppm
Suitable for hardness level	Upto 500 ppm
1-Year Comprehensive Warranty	Yes (including all filters and RO membrane)

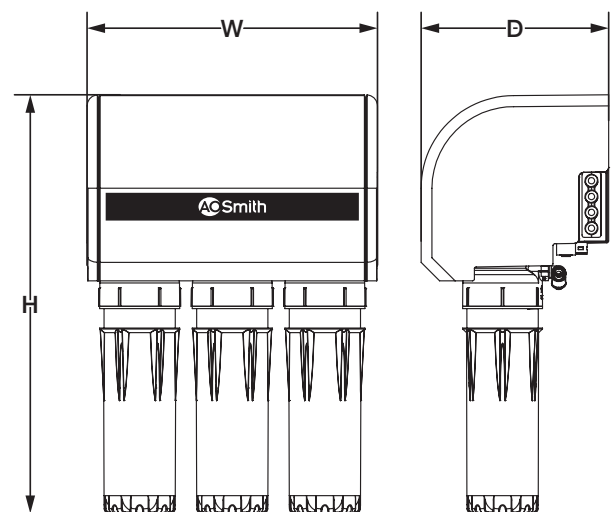

SCAN IT  
TO KNOW MORE



Water Purifiers

Manufactured by

**A. O. Smith India Water Products Private Limited**

Plot No. 300, Phase - II, KIADB Industrial Area, Harohalli,  
Kanakapura Taluk, Ramanagara District,  
Karnataka - 562 112, India.

CIN: U31909KA2006PTC040282

Call **1860 500 2468** or visit **www.aosmithindia.com**

<https://www.facebook.com/aosmithin> | <https://twitter.com/AOSmithin> | <https://instagram.com/aosmithindia>