

## Pre-Installation Literature

### On Receipt

It is our policy to promote safe delivery of all orders. This product shipment has been thoroughly checked, packed and quality certified before leaving our factory.

### Visible Loss or Damage

If any of the goods called for on the bill of lading or express receipt are damaged or the quantity is short, do not accept them until the freight or express delivery agent makes an appropriate notation on your freight bill or receipt.

### Concealed Loss or Damage

When a shipment has been delivered to you in apparent good condition, but upon opening the packaging if any loss or damage has taken place while in transit, inform the carrier's agent / A. O. Smith representative immediately.

### About this manual

This manual is a guide to good practice for operating and periodic maintenance of the A. O. Smith X9 / X9 Black / Z5 Pro RO Water Purifier.

This does not contain the full servicing procedures necessary for continued successful operation of this product. The services of A. O. Smith Company Authorised Service Technician must be employed periodically on the same. Do not operate before reading manual supplied with this product.

Please follow instructions in this manual to ensure personal safety and proper operation of this product. A. O. Smith assumes no liability for installation or servicing performed by any unauthorised personnel. Always install, operate, inspect and maintain this product in accordance with all applicable standards. Please store this user manual carefully for any future reference.

### Disposal of this Product

(Waste Electrical and Electronic Equipment)



This marking on the product, accessories or User Manual indicates that the product and its electronic accessories (e.g. Remote, batteries and other replaceable electronic accessories) should not be disposed of with other household waste at the end of their working life. To prevent possible harm to the environment or human health from uncontrolled waste disposal, please separate these items from other types of waste and recycle them responsibly to promote the sustainable re-use of material resources.

Household users should contact their local government office, for details of where and how they can take these items for environmentally safe recycling. This product and its electronic accessories should not be mixed with other commercial wastes for disposal.

1

## General Instructions

### Safety

Your safety and the safety of your loved ones is paramount. There are several safety related messages in this manual, which have been provided during various steps such as the installation, operation and maintenance of your A. O. Smith X9 / X9 Black / Z5 Pro RO Water Purifier. These messages point out potential hazards and also educate on how to reduce any potential risks. Please always read and follow all safety messages as provided in this user manual.

	This is the safety alert symbol. This symbol alerts you to potential hazards that can hurt you and others. All safety messages will follow the safety alert symbol and either the word "DANGER" or "WARNING".
	Indicates an imminently hazardous situation which, if not avoided, will result in death or serious injury.
	Indicates a potentially hazardous situation, which if not avoided, could result in death or serious injury.
	Indicates a potentially hazardous situation which, if not avoided, may result in minor or moderate injury or property damage.

### IMPORTANT

These instructions have been written as a guide for the proper installation and operation of your Water Purifier. A. O. Smith will not accept any liability where these instructions have not been followed. However, for your safety and to avoid damage caused by improper installation, it is recommended that Water Purifier must be installed by A. O. Smith Company Authorised Service Technician.

Before proceeding with the installation instructions:

1. Inspect the Water Purifier and its component parts for possible damage. Do Not install or attempt to repair any damaged component parts. If you detect any damage in the Water Purifier, please contact the dealer where the Water Purifier was purchased or call A. O. Smith Customer Care Centre.
2. Verify that the voltage being supplied corresponds to that which is mentioned in the A. O. Smith X9 / X9 Black / Z5 Pro RO Water Purifier manual.

Note: This manual refers to the three models X9 RO, X9 Black RO and Z5 Pro RO Water Purifiers. Based on the product purchased, customer needs to refer the respective illustrations.

2

## Key Features of your A. O. Smith X9 / X9 Black / Z5 Pro RO Water Purifier



### Baby Safe Water with 8-Stage Purification

8S TECHNOLOGY: Pre-filter + ART™ MAX + Sediment filter + CB filter + Side Stream RO membrane + CFM + Alkaline filter + SCMT (Post Carbon block + SCMT). In A. O. Smith X9 / X9 Black / Z5 Pro RO Water Purifier 100% of the water passes through the RO Membrane and Double Purified by SCMT.



### Double Protection with RO + SCMT (Silver Charged Membrane Technology)

SCMT is an additional stage of purification to prevent any potential secondary microbial contamination post RO purification. Double protection ensures purified and healthy water.



### Digital Display

Digital display for simple and intelligent display of information



### Advance Alert Technology

Indicates in advance when the RO membrane and other filters need to be changed.



Since 1874

Product colour and image shown may vary from the actual product.  
Part No. : 335300-151\_A Date: 20-12-2024

**AC Smith**  
Innovation has a name.

**Water Purifier**  
X9 / X9 Black / Z5 Pro

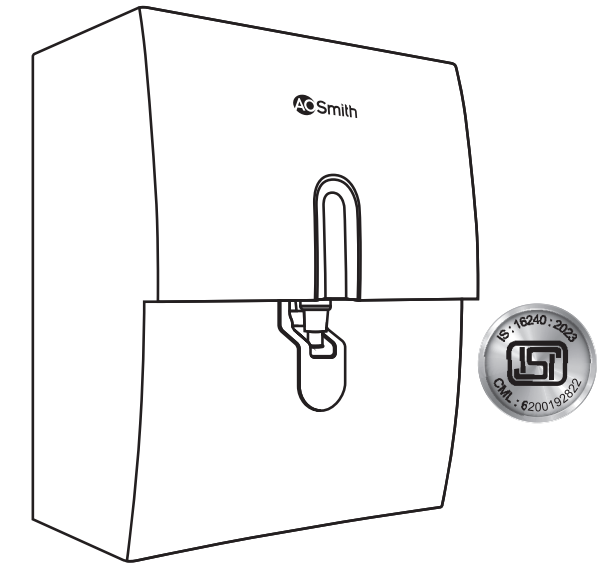

## User Manual

## Introduction

A. O. Smith X9 / X9 Black / Z5 Pro RO Water Purifier uses one of the latest technologies that is used in water purification process. A. O. Smith X9 / X9 Black / Z5 Pro RO Water Purifier works under the principle of RO (Reverse Osmosis) technology which is found to be one of the most effective process. In this process water under pressure is passed through a semi-permeable membrane. Purified water is collected for drinking in a storage tank and impurities in the water are flushed to the drain.

### Why water purification is important?

Water purification, today is essential due to the presence of harmful contaminants present in the water supply. Rapid urbanisation and speedy industrial growth have led to significant pollutants and contaminants being found in the water supply. Below is a list of some of the harmful contaminants found today in the water supply which if consumed in excess can be detrimental to human health.

- TDS (Total Dissolved Solids) like Nitrates, Chlorides, Sulphates etc.
- Pesticides and VOC (Volatile Organic Compounds).
- Heavy metals like Mercury, Arsenic, Lead, Chromium, Cadmium etc., imbalanced pH.
- Micro-organisms such as pathogenic bacteria, virus, protozoa and cysts.

A. O. Smith X9 / X9 Black / Z5 Pro RO Water Purifier removes excessive TDS (Total Dissolved Solids) in water by more than 95%. A. O. Smith X9 / X9 Black / Z5 Pro RO Water Purifier reduces heavy metals, removes pathogens and balances the pH value. By this, it ensures you safe and great tasting water.

### How does the A. O. Smith X9 / X9 Black / Z5 Pro RO Water Purifier work?

A. O. Smith X9 / X9 Black / Z5 Pro RO Water Purifier has 8 stages of purification system, wherein the water is passed through the various stages and progressively filtered to get purified water which is stored in the in-built storage tank.

#### Stage 1 and Stage 2 – Pre-filter + ART™ MAX (Advance Recovery Technology™)

The Pre-filter is used to remove physical contaminants such as dirt, dust, soil particles, turbidity present in the water and the ART™ MAX (Advance Recovery Technology™) is scale control media which conditions the water to reduce scaling potential in water.. This improves the life of the Sediment filter.

#### Stage 3 – Sediment filter

The Sediment filter is used to remove fine and coarse physical contaminants present in the water. This improves the life of the CB filter.

#### Stage 4 – CB (Carbon block) filter

Then water is passed through CB (Carbon block) filter, which reduces harmful chemicals like pesticides, volatile organic compounds, residual chlorine etc. It also adsorbs bad taste and odour causing organic compounds from water.

#### Stage 5 – RO (Reverse Osmosis) membrane

RO membrane contains semi-permeable membrane wherein the water is passed through the semi-permeable membrane to remove TDS (Total Dissolved Solids) and heavy metals like mercury, arsenic, lead, chromium, cadmium etc. It also removes micro-organisms like bacteria, virus, protozoa and cysts. The preservative used in the RO membrane is food-grade Sodium meta bi-sulphate.

3

### Stage 6 and Stage 7 – CFM + Alkaline filter

This filter is the combination of copper fortification technology and Alkaline Mineraliser Technology. Copper fortification technology fortify the goodness of copper in water and act as polisher to enhance the taste of water. Alkaline Mineraliser technology ensures water in pH range of 7 to 8.5 and it adds essential minerals (as per input water condition) such as Calcium and Magnesium back to purified water.

### Stage 8 – SCMT (Silver Charged Membrane Technology)

In the final stage water is passed through SCMT (Silver Charged Membrane Technology) filter which ensures double purification of water making it Safe and Healthy for drinking.

Figure 1

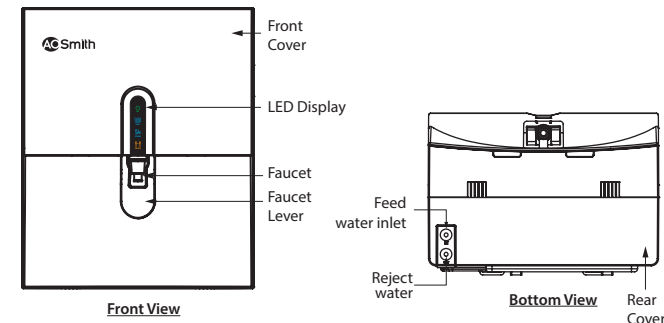

Note: The Ball valve comes along with the product as standard accessories.

4

## Function of indicators

Figure 2

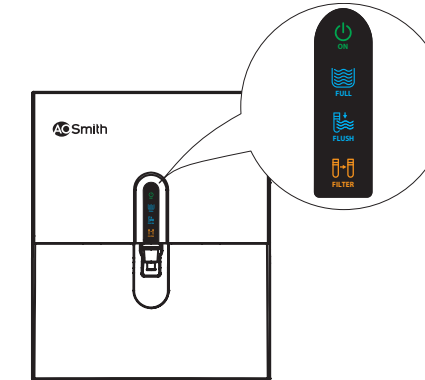

#### Power ON indicator

This indicates, that the system is switch ON/OFF condition.

#### Tank full indicator

This indicates that the Water Purifier tank is full.

#### Auto flush indicator

This indicates flushing is in progress. Every time the water purification process is activated the auto flushing mechanism cleans the RO membrane. It enhances the life of RO membrane.

#### Filter change indicator

This indicates that the RO membrane and filters needs to be replaced.

- Filter change indicator starts blinking indicating that the RO membrane and filters life is reaching its end time.
- When RO membrane and filters life reaches its end, Filter change indicator keeps on blinking and the unit stops functioning. The unit stops functioning, approximately 1 month after it starts blinking.

5

## Water flow

Figure 3

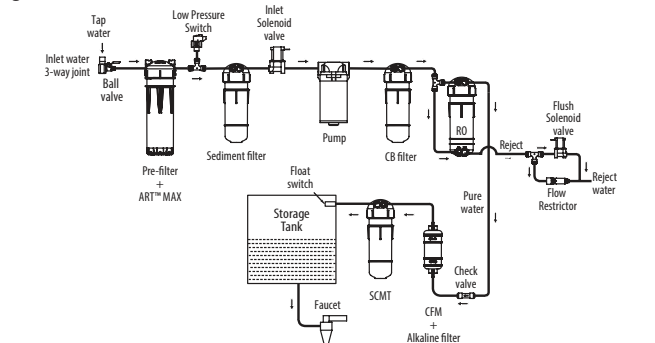

Note: It is recommended not to switch off the Water Purifier and/or turn off the water supply to the product when it is not been used for more than 24 hrs. The purifier has an in-built cleaning mechanism which cleans the RO membrane every 24 hrs. by flushing it. This feature protects the RO membrane and ensures longer life.

## Electrical Diagram

Figure 4

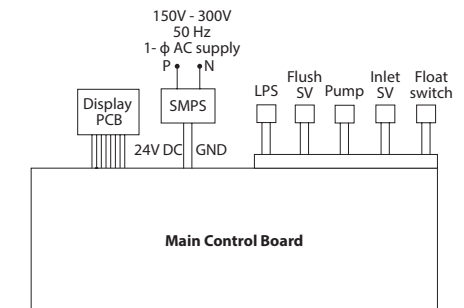

6

## Safety Precautions

### Electrical Safety

Even though these products are designed keeping highest safety standards in mind, there are certain Do's and Don'ts which need to be followed while using these products.

Power plug must be used with a 230 V outlet. It is recommended to connect the product to the power supply only with the plug that is provided with the purifier. Do not pull out or touch power plug with wet hands to avoid electrical shock.

Figure 5

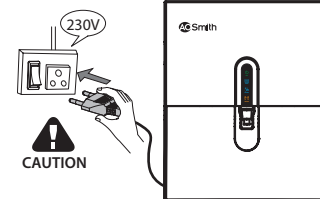

Product should be installed only by A. O. Smith Company Authorised Service Technician. Do not open the purifier for cleaning the filters or for any part replacements. This must be done only by A. O. Smith Company Authorised Service Technician.

Figure 6

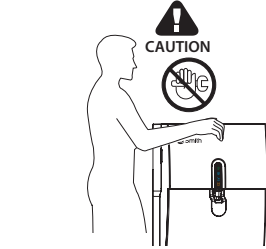

Make sure that the feed water is tested before installation (Refer page 10). Do not install the product if the TDS and Hardness are more than that prescribed in the recommended feed water conditions (Refer page 13).

Figure 7

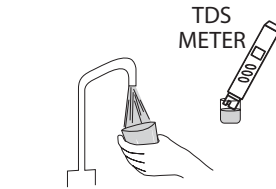

Install the product away from direct sunlight.

Figure 8

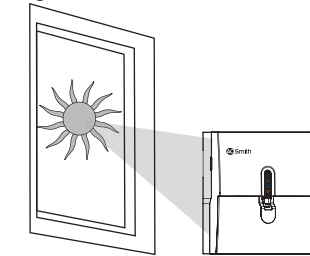

7

## How to use

1. Turn ON the water connection through the ball valve.

Figure 9

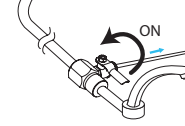

2. Switch ON the power supply.

Figure 10

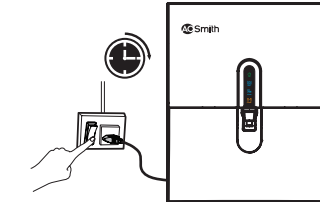

**Flushing procedure:** This is auto-flushing unit. The flushing will be completed by 4 minutes (approx.).

Note: Discard the first two tanks of pure water, before you start using it for consumption.

3. To dispense water continuously, lift up the water faucet lever for the continuous water flow.

Figure 11

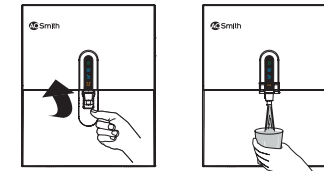

Note: Water is dispensed continuously only by lifting the faucet lever upwards.

8

4. To stop the water flow, pull down the water faucet lever to position 2 slowly and then to initial position. This avoids splashing of water.

Figure 12

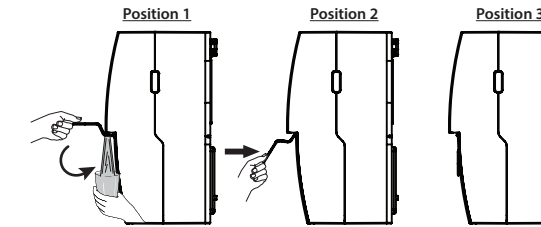

### NOTICE

- Discard the first cycle of pure water, before you start using it for consumption.
- Make sure to discard the water in the storage tank if you have not used the purifier for more than 2 days.

### Cleaning of Tank

Switch off the unit and add one A. O. Smith disinfectant tablet and wait for 10mins. Discard the water through the faucet and make sure to remove the excess water. Switch On the unit and drain 2 tanks of water through faucet before consuming.

Frequency of cleaning: Once in a year along with annual maintenance.

### How to use TDS meter?

- Insert the button cell inside the TDS meter.
- Switch ON the TDS meter.
- Fill water in the cap and immerse the TDS meter.
- Press the HOLD button and take it out of the water to view the reading.
- If the meter displays the 'x10' symbol, it means that you must multiply the reading by 10.
- Remove the button cell from the TDS meter when not in use.

### Calibration and Maintenance of TDS meter

The TDS meter are factory-calibrated and designed to stay consistent. Maintenance of the TDS meter will be done along with the yearly product maintenance.

9

## Troubleshooting

Your A. O. Smith X9 / X9 Black / Z5 Pro RO Water Purifier may not function at its desired capability if used incorrectly. This may not necessarily mean that the product is faulty. For instances like these, please follow the steps given below to troubleshoot the problem without the help from a certified technician. If the problem still persists, please call Customer Care Centre immediately.

Problems	Possible Cause(s)	Solution
Change in water taste.	Has the purified water been stored in the tank for long time?	Drain the stored water from the storage tank through faucet.
	RO membrane / filters may require replacement.	Call Customer Care Centre for RO membrane / filters replacement.
	Has the raw water quality changed?	Call Customer Care Centre.
Decreased flow of purified water.	Check if there is no water flow through reject line.	Switch OFF the Water Purifier and call Customer Care Centre.
	Check whether the tap/ball valve is closed.	Open the tap/ball valve.
Less / No reject water.	RO membrane / filters may be clogged or damaged.	Call Customer Care Centre for RO membrane / filters replacement.
	Check if the reject water tube is bent.	Clear the bent in the reject water tube.
Less/No purified water.	Check if the reject water tube is blocked.	Switch OFF the Water Purifier and Call Customer Care Centre.
	Check whether there is water supply in the tap.	If not, take the help of a plumber to set it right.
	Check whether tap/ball valve is closed.	Open the tap/ball valve.
	Check if either Filter change is blinking.	Call Customer Care Centre for RO membrane/filters replacement.
	None of the above.	Call Customer Care Centre.

10

Tank full LED blinks continuously 	Over flow error.	Switch OFF the Water Purifier and call Customer Care Centre.
Power LED blinks continuously 	Low pressure alarm is triggered indicating that the system input water pressure is not in the required range.	Check feed water supply to the purifier. If problem still persists, switch OFF the Water Purifier and call Customer Care Centre.
Flush LED blinks continuously 	RTC error.	Switch OFF the Water Purifier and call Customer Care Centre.
Filter change LED blinks and unit is functioning 	RO membrane or filters life is about to end.	Switch OFF the Water Purifier and call Customer Care Centre for RO membrane or filters replacement.
Filter change LED blinks and unit is not functioning 	RO membrane or filters life ends.	Switch OFF the Water Purifier and call Customer Care Centre for RO membrane or filters replacement.

Note: Call Customer Care No. 1860-500-2468.

## Technical Specifications

Model	A. O. Smith X9 / X9 Black / Z5 Pro RO
Product Dimensions (H x D x W)	460 mm x 270 mm x 380 mm
Net Weight	8.5 kgs (approx.)
Gross Weight	12.5 kgs (approx.)
Production rate*	Upto 15 litres per hour
Storage tank capacity	5 litres (approx.)
Purification technology	RO (Reverse Osmosis)

11

8 Stage Purifying Technology	Pre-filter + ART™ MAX + Sediment filter + CB filter + Side Stream RO membrane + CFM + Alkaline filter + SCMT (Post Carbon block + SCMT)
Material of construction for plastic parts	Food safe, non-toxic, engineering grade plastics
Pump type	Diaphragm pump, 24VDC
Input Voltage	150 – 300 VAC, 50 Hz
Power rating (Max)	48 Watts
Pressure Rating***	5 psi to 30 psi
% Recovery**	Minimum 40%
TDS rejection**	≥95% (approx.)
Input water temperature	5°C to 45°C

\* Production rate depends on variable factors such as feed water pressure, feed water characteristics and condition of the membranes and filters.

\*\* Recovery and TDS rejection percentages also depend on variable factors such as life and condition of the membranes and filters, feed water pressure, feed water characteristics.

\*\*\* If input pressure exceeds 30 psi, a pressure reducing valve needs to be installed at the feed line. If the pressure is lower than 5 psi, a booster pump needs to be installed. Ensure you buy them from A. O. Smith Company Authorised Service Technician.

12

## Recommended input feed water quality for the optimum performance of your product

*Recommended Feed Water Quality	
Parameter	Limits
Total Dissolved Solids (TDS)	Up to 2000 ppm
Total hardness	Up to 500 ppm
Turbidity	Up to 5 NTU
Iron	0.3 ppm (max.)
Feed water pressure	5 psi to 30 psi / 0.034 Mpa to 0.206 Mpa
Feed water temperature	5° C to 45° C
<b>Caution:</b> The RO system is not recommended for arsenic level above 0.1 mg/litre, fluoride level above 8.0 mg/litre and iron level above 0.3 mg/litre.	

\*The performance of the all filters depends on the input water conditions as mentioned above.

13

## Warranty details/recommended filter change:

As per the warranty, all the filters, including RO membrane needs to be replaced when the Filter change indicator blinks (Refer page 5) after 6000 litres of water consumption or 1 year whichever comes first.

Consumable Filters	Average Service Life
Pre-filter + ART™ MAX (Advance Recovery Technology™)	6000 litres*
Sediment filter	6000 litres*
SCB filter*	6000 litres*
Side Stream RO membrane	6000 litres*
CFM + Alkaline filter*	6000 litres*
SCMT	6000 litres*

\*The filter media used will not cause any of the parameters in the purified water to exceed acceptable limits specified in IS 10500 (2012).

\*As per standard test conditions. Filters are designed for 6000 litres of purified water.

14